



## Perfect Fit Tensioned Blinds

## YOU SHOULD HAVE

### PERFECT FIT ITEM LIST

Perfect Fit  
frame and blind

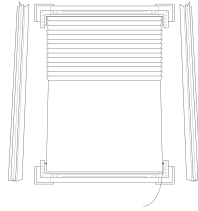

8 x screws (2 per  
corner)



Bracket

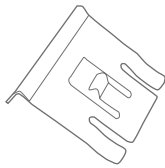

### TOOLS REQUIRED

Screwdriver

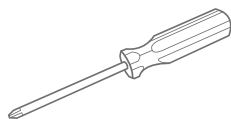

**NOTE:** for blinds with frame, the wand will always be attached to the back of the side sections of the frame. For blinds without a frame, the wand will be inside the head rail of the blind.  
Sunwood: when the wand is wider than the blind, the wand will be sent as a separate package.

**THE INSTALLATION OF THIS PRODUCT SHOULD BE CONDUCTED BY SOMEONE COMPETENT IN DIY.**

## STEP 1

### PUT THE FRAME TOGETHER

#### 1.1

Lay all parts of the frame/blind out face down on a clean even surface.

Your blind will be attached to the top section of the frame. The bottom frame section will be attached using the tension cords

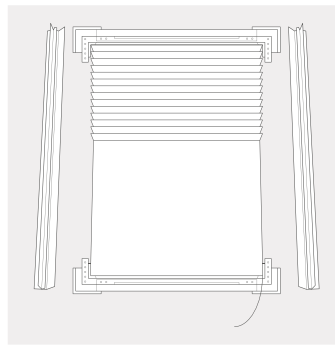

#### 1.2

Starting from the left hand side, securely push the frame section into the corner joints, starting at the top. Repeat for the right hand side.

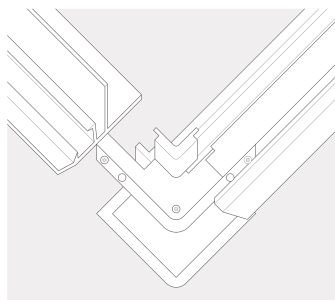

#### 1.3

Your Perfect Fit frame and blind are ready to fit.

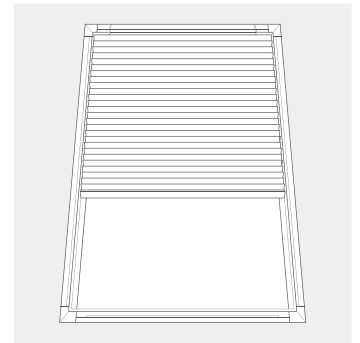

Attach the hook onto the spring. Test operation of blind. If the tension needs to be adjusted, loosen the screw in the locking ring. To increase tension make the cord shorter. To reduce tension make the cord longer and tighten the screw in the locking ring.

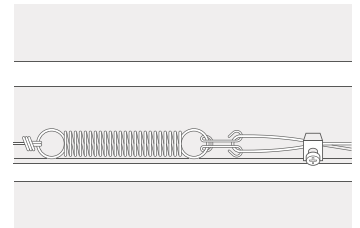

## STEP 2 - FITTING STEP 3

### ATTACH THE BRACKETS

#### 2.1

Press the flat edge of the bracket underneath the window seal. Bracket should be placed with the small tab facing outwards. Align the brackets with the holes in the frames

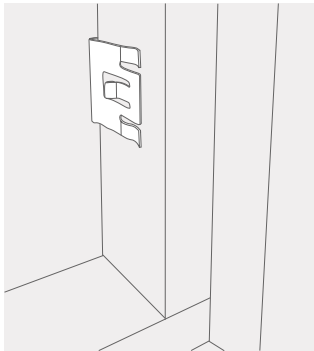

**TIP:** A credit/debit card can be used as a template to align the top & bottom holes. Place the card as shown.

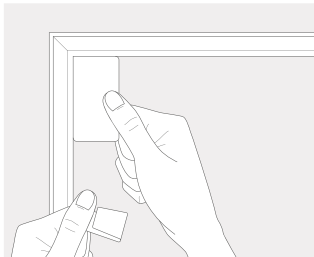

#### 2.2

Blinds over 1100mm drop will have an additional punch hole, centred between the top and bottom holes. Align the additional brackets accordingly.

**TIP:** If you find that the brackets are difficult to place behind the window seal, you can use some washing up liquid as a lubricant on the flat part of the bracket. Once all the brackets are fitted clean any excess from the window surface.

### ATTACH THE FRAME & BLIND TO THE WINDOW

#### 3.1

Line up the holes in the Perfect Fit frame with the brackets.

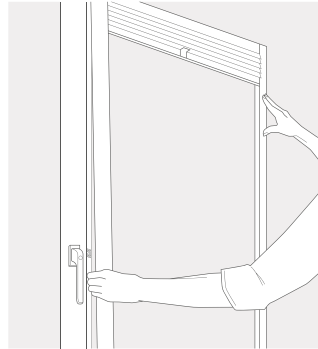

#### 3.2

Firmly press the frame onto each bracket one side at a time.

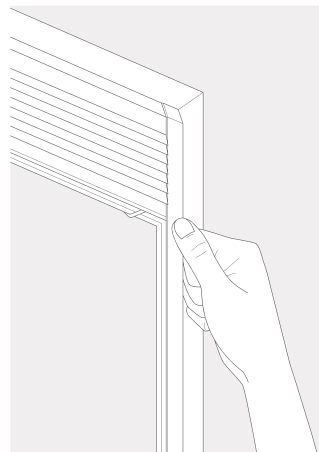

Your frame and blind are now installed

PLEASE READ THE INSTRUCTIONS BEFORE OPERATING THIS PRODUCT

## OPERATION INSTRUCTIONS

### OPERATING YOUR BLIND

#### TO RAISE & LOWER THE BLIND

Simply raise and lower the blind to the desired position by firmly holding the handle.

Slats need to be open when raising or lowering the blind.

#### SLAT ANGLE

To adjust the angle of the slats, twist the wand.

### MAINTENANCE

The product is maintenance free however we recommend that regular visual checks are completed to ensure that no components have been damaged, which could result in operating difficulties and/or cause a safety risk.

If any maintenance is required we recommend that the work is carried out immediately, by a reputable blind company.



**make it<sup>TM</sup>  
safe**

**BBSA**<sup>®</sup>  
BRITISH BLIND & SHUTTER ASSOCIATION

## WARNING

Young children can be strangled by loops in pull cords, chains, tapes and inner cords that operate the product.

To avoid strangulation and entanglement, keep cords out of the reach of young children. Cords may become wrapped around a child's neck. Move beds, cots and furniture away from window covering cords.

Do not tie cords together. Make sure cords do not twist and create a loop.

